



User Manual

ADDRESSABLE I/O MODULE
BP-FD-AIO319



Enjoy it.

Instruction Manual of BP-FD-AIO319

Addressable I/O Module

----- Please read this Manual carefully before installing and using the product. -----

I. Overview

The BP-FD-AIO319 Addressable I/O Module is used with BP-FD-ACP300-1L fire alarm control panel. It is mainly used to realize an output control for fire linkage equipment (such as smoke dampers, blow valves and fire dampers) and receive the feedback signals of the fire linkage equipment so that a judgment on whether or not the fire linkage equipment is operating normally can be done. The BP-FD-AIO319 I/O module should be installed on the DZ-9056 base.

II. Feature and technical parameters

1. Executive standard: EN54-18
2. Operation voltage: loop DC24V (polarity-insensitive); power DC24V (polarity-insensitive)
3. Quiescent current: loop current $< 0.8\text{mA}$; power current $< 2\text{mA}$
4. Action current: loop current $< 5\text{mA}$; power current $< 15\text{mA}$
5. Capacity of the output control contact: $1\text{A}@\text{DC}30\text{V}$
6. Operation indicator: The inspection indicator will blink once about every 12 seconds in the inspection status or remain lit in the output status; the input indicator will remain lit in the feedback status.
7. Operating environment: Temperature: $-10^{\circ}\text{C} \sim 55^{\circ}\text{C}$; RH: $\leq 95\%$ ($40^{\circ}\text{C} \pm 2^{\circ}\text{C}$, without condensation)
8. External dimensions: $86 \times 86 \times 41$ (mm, With base)
9. Weight: about 148g (With base)



III. Instructions for use

1. Terminal description (see Fig.2)

Terminal Name	Function
D1,D2	DC24V power input, non-polarized
L1,L2	Loop connection, non-polarized
TO+,TO-	Voltage-free Input, factory default mode is normally open. For normally closed mode, Jumper JP4(see Fig1)'s Pin1 & Pin2 should be shorted.
NO1,NO2	Normally open contact. For voltage output, NO1 and NO2 should be connected with DC24V positive and DC24V negative respective.
NC1,NC2	Normally closed contact.
COM1,COM2	Common contact. When set to voltage output, the controlled equipment should be connected between COM1 and COM2.

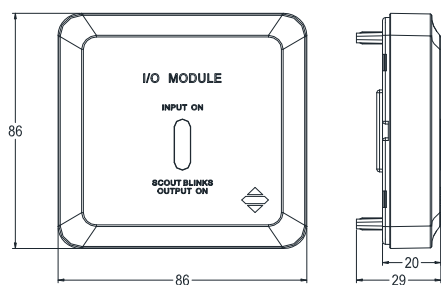

Fig. 1 Main part (unit mm)

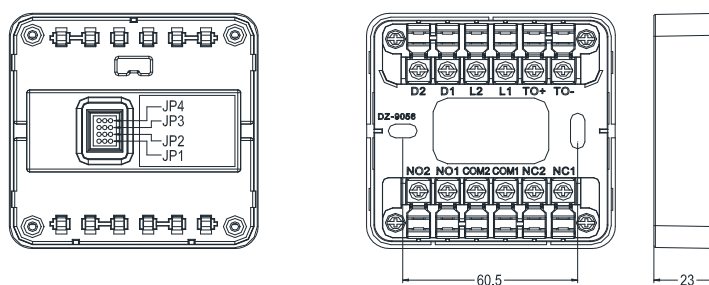

Fig. 2 Base (unit mm)

2. Jumper setting and wiring method

- 1) For normally close input, short JP4's Pin 1 & Pin2; for normally open input, short JP4's Pin 2 & Pin3.
- 2) For project application, Jumper JP1, JP2, JP3's Pin1 & Pin2 should be shorted (Pin2 & Pin3 are shorted as factory default, only for production test).
- 3) The ends of input and output circuit should correctly use a 47K Ω resistor (shown in Fig. 3), so that the Addressable I/O Module can identify the short-circuit fault or open-circuit fault of the input and the output circuit.
- 4) For voltage output, NO1 and NO2 should be connected with DC24V positive and DC24V negative respectively, and a 1N4007 diode should be in series between COM1 and COM2 then connected with the controlled equipment. The details of the wiring method is shown in Fig. 3.

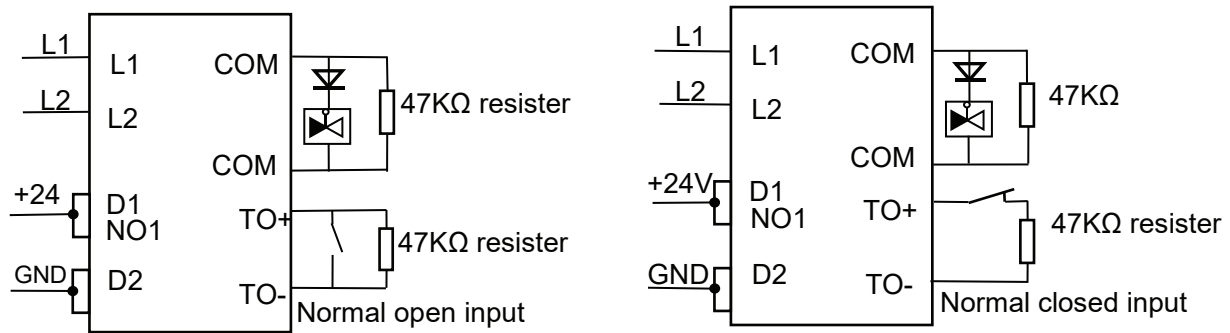

Fig 3. Wiring method of Voltage Output

IV. Installation and debugging

1. Make sure the BP-FD-AIO319 module matches the type given on the construction drawings.
2. Connect the 4-pin coding plug on the coder with the 4-pin coding socket (see Fig.1) on the main body of the BP-FD-AIO319 module and then set the coder with the coding function and compile the correct address code to finish the address coding.
3. To enhance the RF immunity of the CIE, the decoupling module of DM-XCDL25/5A should be connected in series into the signal loop (L1 & L2).
4. Conduct correct wiring as instructed in Fig.3 or Fig.4.
5. Use two M4 screws to fix the module base via the two elliptic screw holes shown in Fig.2 and then insert the main body of the BP-FD-AIO319 module into the module base and make sure they contact each other well.
6. After the module is installed and checked, connect the power supply of the fire alarm control system. Upon successful login, the inspection indicator of the module will blink once about every 12 seconds, which suggests that the BP-FD-AIO319 module has begun to operate.
7. Conduct debugging after the installation is completed. Make the fire alarm control system send out a starting signal and have the starting signal sent by the module to the fire linkage equipment connected with it. After that, the fire linkage equipment will operate correspondingly and the inspection indicator of the module will be lit. The operating fire linkage equipment will give a feedback signal. After receiving the feedback signal, the module will have its input indicator lit, which suggests that it has begun to operate normally.
8. After the debugging, reset the BP-FD-AIO319 module and related equipment.

V. Precautions

1. Do not connect the output to the AC signal, or the BP-FD-AIO319 module may be damaged.
2. For active output, NO1 should be connected with DC24V positive, and NO2 with DC24V negative.
3. Confirm the type of the input equipment connected with the module (feedback equipment or fire alarm equipment) and have the corresponding equipment type of the module set in the fire alarm control panel. After automatic login, the BP-FD-AIO319 module will treat the input equipment as fire alarm equipment by default.

For Inquiries, Please contact:

Security Shop

Vladimira Popovica 6/6/A606

11070 Novi Beograd, Serbia

Tell: +381 11 318 68 68

office@securityshop.rs

Imported/Distributed by Security Shop doo

BLAUPUNKT and the BLAUPUNKT logo are trademarks of
TALISMAN BRANDS (Luxembourg) S.A.R.L. and are used
under license from Talisman Brands, Inc.

BLAUPUNKT licensees are solely responsible for
the BLAUPUNKT branded products manufactured,
distributed and sold under license.

www.blaupunkt.com