

Network Cabinet

HYU-NE-NCW6002



Main material

All is made of high-quality SPCC Cold Rolled Steel

Thickness:

Square-hole post: 1.2mm

Others: 1.0mm

Features

- **Surface Finish**

The cabinet includes a powder coating surface finish which ensures it remains grease and corrosion free. The surface finish complies with relevant ROHS requirements.

- **Strength and Durability**

With good stiffness and strength, the maximum loading is 50kgs. The cabinet can be internally tightened once installed, so as to prevent theft or accidental collision. The cabinet can be installed either at wall height or on the floor. In the case of floor installation, castor wheels or feet can be added.

- **Easy installation**

Pre-fitted with a wall mounting plate, this series cabinet is easy to install. Quick open side door and rear doors also make the cabinet easy to maintain.

- **Appearance**

Removable left and right side and front door, front door come with tempered glass. Elegant design, exquisite craftsmanship, precision size, modern, make your project look nice.

Structure Diagram

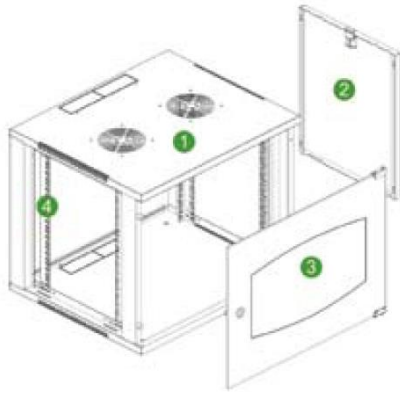

Product Standard Configuration

Model	HYU-NE-NCW6001				
S/N	Specification	Qty	Material	Surface Finish	Remark
1	Frame	1	SPCC t1.0	Powder coated	----
2	Side panel	2	SPCC t1.0	Powder coated	----
3	Front door	1	4MM toughed glass	----	May choose the fitting
4	19 " rails	4	SPCC t1.2	Powder Coated	----
A	M6 screw & nuts	10/20	Steel	Nickel-plated	20pcs for over 15U
B	Trox tooling	1	Steel	Black	----

Specification

Model	Capacity (U)	Size (mm)			Packing dimension (mm)
		Width	Depth	Height	
HYU-NE-NCW6002	6	600	450	315	Flat package