

HYUNDAI
ELECTRONICS

Network Switch

HYU-NE-SW-U5001

USER MANUAL

HYU-NE-SW-U5001



Packing List

- ▶ 1*Network Switch
- ▶ 1*Power Adaptor
- ▶ 1*User Guide (Warranty Card is included)

Please contact us immediately if there is any shortage or damage

Feature

- 5* 10/100/1000Mbps auto-sensing RJ45 ports, auto MDI/MDIX.
- IEEE 802.3, IEEE 802.3u, IEEE 802.3x, IEEE 802.3ab.
- Support 10/100/1000M auto-negotiation for full duplex and half duplex. Plug and play, no need more configuration.
- Support desktop/wall mounted installation.

Technical Specification

Network Media: 10Base-T: Cat.3/4/5; 100BASE-TX: Cat.5/Above
1000BASE-TX: Cat.5e/Above

Standard Protocol: IEEE802.3, IEEE802.3u, IEEE802.3x, IEEE 802.3ab

Forwarding Rate: 7.44Mbps@64bytes

Switching performance: Store and Forward Mode/ MAC self-learning. 10G Back-bound

Bandwidth Working Environment: Working Temperature: -20°C~55°C

Storage Temperature: -40°C~70°C

Working Humidity: 10%~90% Non-condensing

Storage Humidity 5%~90% RH (non-condensing)

Dimension: 98x70.7x27mm

Power Consumption: ≤ 2.5w

Installation

HYU-NE-SW-U5001 could be installed on wall or desktop. Wall mounted installation step as below:

1. Posit the install hole according to the slot position in the bottom of the network switch. Tighten the screws (User prepared) and keep an appropriate length for the screw head.
2. Align the bottom of the switch with the screw head and slide it into place.

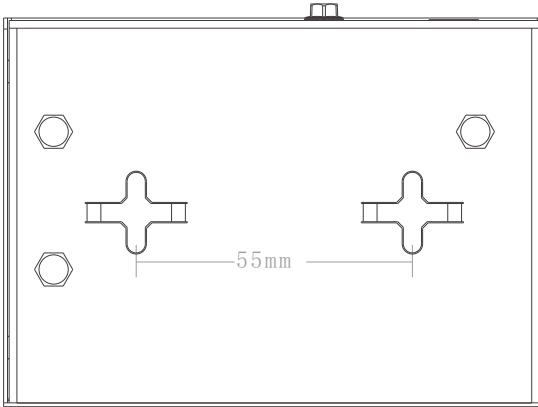

Distance of the mounted holes is 55mm

Application

Plug and play, no need for more configuration.

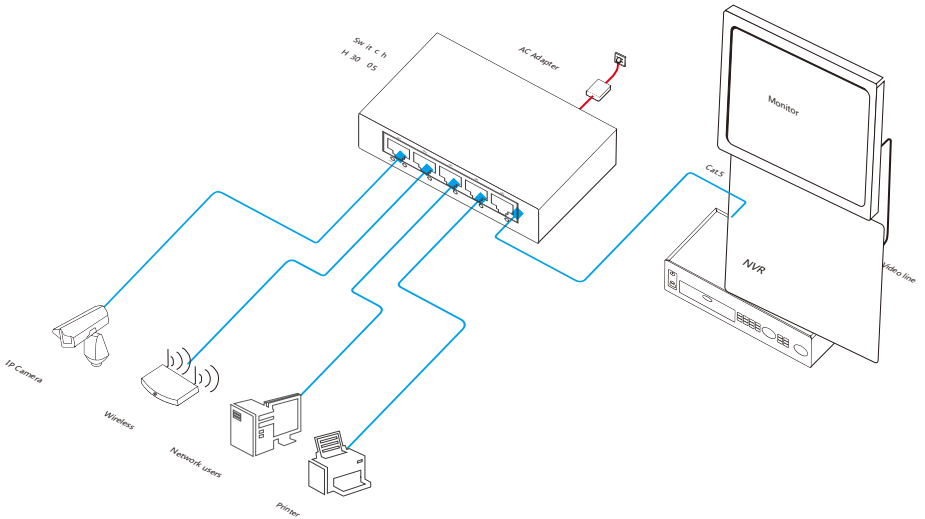

Warranty Card

1. Dear Customer

The loss / malfunction being produced or due to one of factors below is not within maintenance and warranty, and no any economical responsibility borne by HYUNDAI.

1. Loss or malfunction by installing, using, maintaining, keeping the product failure or damage without following the instructions;
2. Out of warranty period;
3. Unauthorized alteration, tear up the product bar code;
4. Bar code or model in product warranty card are not match with the product itself;
5. Unauthorized changes to inherent setting file or repair ;
6. Accidental or human behavior leading to product damage, such as input inappropriate voltage, high temperature, water, mechanical damage, broken, serious oxidation or rust products etc;
7. Damage caused by loading and unloading during transportation;
8. Damage caused by fire, electric shock, outside object collapse or other natural disasters.
9. Other damage that is not caused by product itself design, technology, manufacturing and quality.

2. Special Instruction

Please noted HYUNDAI wont take the liability for warranty if following factors: obvious hard damage, cracks, broken feet, serious deformation, power cord damage, broken wire, bare core and other phenomena.

Warranty is limited to the host and power supply, while package and all kinds of wiring, software products, technical information and other accessories are not covered within the warranty.

Any failure or malfunction due to equipment's itself and no scratches on the surface, HYUNDAI would exchange same model or similar technical specification model product within 15 days from the date of selling. If tested normal by HYUNDAI technical department, the equipment would be sent back. Please provide the related invoice and warranty card when needing the service. If you can not provide the above documents, the product's free warranty period will be calculated from the date of its production.

3. Technical Support

Before send back products for repair, please kindly call our technician for affirmation, also you can visit our official website: www.onvcom.com and communicate with our technician on line.

4. The statement is valid from the launching date.
5. We reserves the rights to final interpretation and change to the content of the warranty statement

For Inquiries, Please Contact:

Security Shop
Vladimira Popovica 6/6/A606
11070 Novi Beograd, Serbia
Tell +381 11 318 68 68
office@securityshop.rs