

HYUNDAI
ELECTRONICS

DIGITAL DOOR LOCK

HYU-AC-SAXK4M001

USER MANUAL

INTRODUCTION

The XK Series Device is a single door multifunction standalone access controller or a Wiegand output reader. It uses Atmel MCU assuring stable performance. The operation is very user-friendly, and low-power circuit makes it long service life.

The XK Series Device supports 1,000 users (998 common users + 2 panic users), all user data can be transferred from one to another. It supports multi access modes in either card access, PIN access, Card + PIN access, or multi cards/PINs access. It has extra features including block enrollment, interlocked, Wiegand 26~37 bits interface...etc.

Features

- > Bluetooth Module(Optional), to connect mobile for opening door
- > Fashion design, all-metal key button
- > Metal Case, Anti-vandal
- > Waterproof, conforms to IP66
- > One relay, keyboard programmer
- > 1,000 users (998 common users + 2 panic users)
- > PIN length: 4~6 digits
- > Card type:
 - EM version: 125KHz EM card
 - HID & EM version: 125KHz HID & EM cards
- > Wiegand 26~37 bits input & output
- > Can be used as Wiegand reader with LED & buzzer output
- > Card block enrolment
- > Tri-colour LED status display
- > Integrated alarm & buzzer output
- > Pulse mode, Toggle mode
- > User data can be transferred
- > 2 devices can be interlocked for 2 doors
- > Built in light dependent resistor (LDR) for anti tamper
- > Backlit keypad
- > Low temperature resistance(-40°C)
- > Voltage: 12~28V AC/DC

Specifications

User Capacity	1000
Common User	998
Panic User	2
Operating Voltage	12~28V AC/DC
Idle Current	< 35mA

Proximity Card Reader Radio Technology Read Range	EM or HID & EM 125KHz Proximity Card 2~6 cm
Wiring Connections	Relay Output, Exit Button, Alarm, Door Contact, Wiegand Input, Wiegand Output
Relay Adjustable Relay Output Time Lock Output Load	One (NO, NC, Common) 0~99 Seconds (5 seconds default) 2 Amp Maximum
Wiegand Interface Wiegand Input Wiegand Output PIN Output	Wiegand 26-37 bits (Factory Default: wiegand 26bits, 4 bits) 26-37 bits 26-37 bits 4 bits, 8 bits(ASCII), 10 digits Virtual Number
Environment Operating Temperature Operating Humidity	Meets IP66 -40°C ~ 60°C (-40°F ~ 140°F) 0%RH~98%RH
Physical Colour Dimensions Unit Weight Shipping Weight	Zinc-Alloy Silver L114.5 x W75 x D22mm(Wide) L134 x W55.5 x D21mm(Slim) 360g(Wide) /340g(Slim) 440g(Wide) /420g(Slim)

Carton Inventory

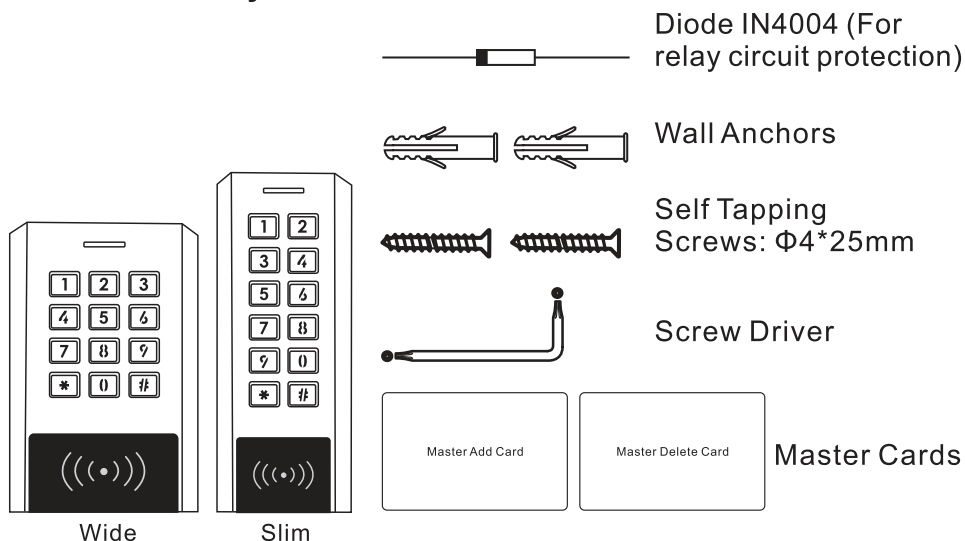

INSTALLATION

- > Remove the back cover from the unit
- > Drill 2 holes(A,C) on the wall for the screws and one hole for the cable
- > Knock the supplied rubber bungs to the screw holes(A,C)
- > Fix the back cover firmly on the wall with 4 flat head screws
- > Thread the cable through the cable hole(B)
- > Attach the unit to the back cover

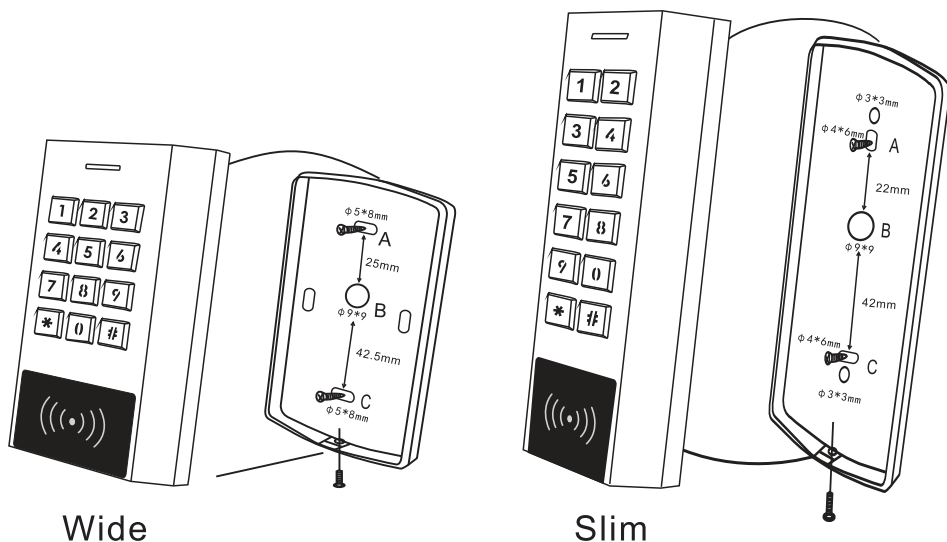

Wiring

Wire Color	Function	Notes
Basic Standalone Wiring		
Red	AC/DC	12-28V AC/DC Regulated Power Input
Black	AC/DC	12-28V AC/DC Regulated Power Input
Pink	GND	Negative Pole
Blue	Relay NO	Normally Open Relay Output (install diode provided)
Purple	Relay Common	Common Connection for Relay Output

Orange	Relay NC	Normally Closed Relay Output (Install diode provided)
Yellow	OPEN	Request to Exit(REX) Input
Pass-Through Wiring (Wiegand Reader or Controller)		
Green	Data 0	Wiegand Input /Output Data 0
White	Data 1	Wiegand Input /Output Data 1
Advanced Input and Output Features		
Grey	Alarm Output	Negative contact for Alarm
Brown	Contact Input	Door/Gate Contact Input (Normally Closed)

Sound and Light Indication

Operation Status	LED	Buzzer
Stand by	Red light bright	—
Enter into programming mode	Red light shines	One beep
In the programming mode	Orange light bright	One beep
Operation error	—	Three beeps
Exit from the Programming mode	Red light bright	One beep
Open lock	Green light bright	One beep
Alarm	Red light Shines quickly	Beeps

Basic Configure

Enter and Exit Program mode

Programming Step	Keystroke Combination
Enter Program Mode	* (Master Code) # (Factory default is 123456)
Exit Program Mode	*

Set Master Code

Programming Step	Keystroke Combination
1. Enter Program Mode	* (Master Code) #
2. Update Master Code	0 (New Master Code) # (Repeat New Master Code) # (Master code is any 6 digits)
3. Exit Program Mode	*

Set the Working Mode

Notes: the XK Series Device has 3 working modes: Standalone Mode, Controller Mode, Wiegand Reader Mode, choose the mode you use. (Factory default is Standalone Mode / Controller Mode)

Programming Step	Keystroke Combination
1. Enter Program Mode	* (Master Code) #
2. Standalone/Controller Mode OR 2. Wiegand Reader Mode	7 2 # (Factory default) 7 3 #
3. Exit	*

STANDALONE MODE

The XK Series Device can be worked as Standalone Reader for single door. (Factory default mode)---7 2 #

Connection Diagram

Common Power Supply

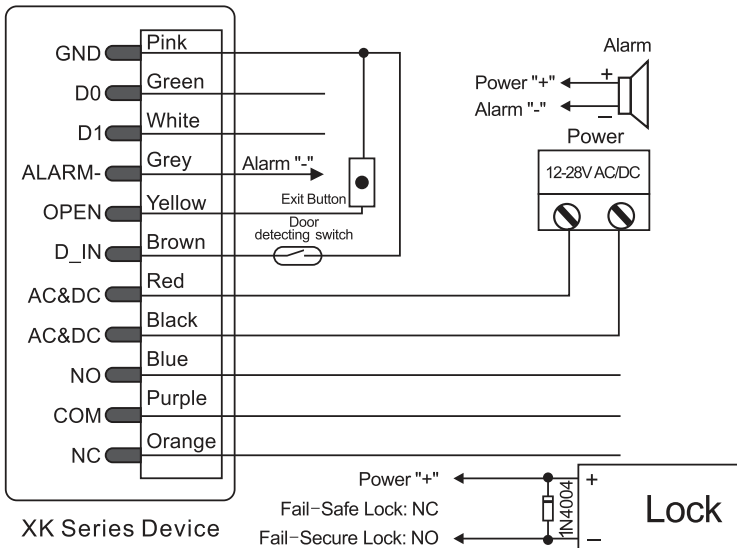

Attention:

Install a 1N4004 or equivalent diode is needed when use a common power supply, or the keypad might be damaged. (1N4004 is included in the packing)

Access Control Power Supply:

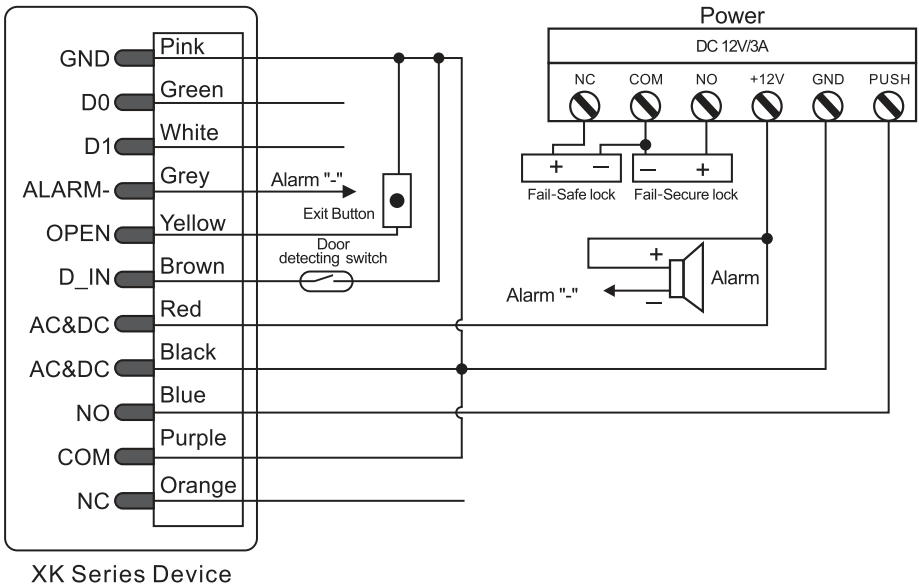

Programming

Programming will vary depending on access configuration. Follow the instructions according to your access configuration.

Notes:

- > **User ID number:** Assign a user ID to the access card / PIN in order to track it. The common user ID number can be any number from 0~997, the panic user ID is from 998~999. **IMPORTANT:** User IDs do not have to be preceded with any leading zeros. Recording of User ID is critical. Modifications to the user require the User ID be available.
- > **Proximity Card :**
 - EM version: 125 KHz industry standard 26bits EM card
 - HID & EM version: 125 KHz industry standard 26bits HID & EM cards
- > **PIN:** Can be any 4~6 digits except 8888 which is reserved

Add Common Users

Programming Step	Keystroke Combination
1. Enter Program Mode	* (Master Code) #
Add Card User	
2. Add Card: Using Auto ID (Allows the XK Series Device to assign Card to next available User ID number) OR 2. Add Card: Select Specific ID (Allows Master to define a specific User ID to associate the card to) OR 2. Add Card: by Card Number OR 2. Add Card: Block Enrolment (Allows Master to add up to 998 cards to the Reader in a single step) Takes 2 minutes to program.	1 (Read Card) # The cards can be added continuously. 1 (User ID) # (Read Card) # (User ID is any number from 0~997) 1 (Input 8/10 digits Card number) # 1 (User ID) # (Card quantity) # (The first card number) # Cards' number must be consecutive; Card quantity = number of cards to be enrolled.
Add PIN User	
2. Add PIN: Using Auto ID (Allows the XK Series Device to assign PIN to next available User ID number)	1 (PIN) # The PINs can be added continuously. (PIN: 4~6 digits)
2. Add PIN: Select Specific ID (Allows manager to define a specific User ID to associate the PIN to)	1 (User ID) # (PIN) # The user ID is any number from 0~997.
3. Exit	*

Add Panic Users

Programming Step	Keystroke Combination
1. Enter Program Mode	* (Master Code) #
2. Add Card: OR 2. Add PIN:	1 (User ID) # (Read Card / Input 8/10 digits Card number) # 1 (User ID) # (PIN) # (User ID is any number from 998~999)
3. Exit	*

Change PIN Users

Programming Step	Keystroke Combination
Note: Below is done outside programming mode, users can undertake this themselves	
1. Change PIN: By Card (There will auto allocate PIN (8888) to cards when adding)	* (Read Card) (Old PIN) # (New PIN) # (Repeat New PIN) #
2. Change PIN: By User ID	* (User ID) # (Old PIN) # (New PIN) # (Repeat New PIN) #
3. Exit	*

Delete Users

Programming Step	Keystroke Combination
1. Enter Program Mode	* (Master Code) #
Delete Card User - Common	
2. Delete Card – By Card OR 2. Delete Card – By ID number OR 2. Delete User – By Card number	2 (Read Card) # The cards can be deleted continuously. 2 (User ID) # 2 (Input 8/10 digits Card number) #
Delete PIN User - Common	
2. Delete PIN – By PIN OR 2. Delete PIN – By ID number	2 (Input PIN) # 2 (User ID) #
Delete Panic User	
2. Delete Panic Card User OR 2. Delete Panic PIN User	2 (User ID) # 2 (User ID) #
Delete All Users	
Delete All User	2 (Master Code) #
3. Exit	*

Set Relay Configuration

The relay configuration sets the behaviour of the output relay on activation.

Programming Step	Keystroke Combination
1. Enter Program Mode	* (Master Code) #
2. Pulse Mode OR 2. Toggle Mode	3 (1-99) # (factory default) The relay time is 1-99 seconds. (1 is 50mS.) (Default is 5 seconds) 3 0 # Set the relay to ON/OFF Toggle mode
3. Exit	*

Set Access Mode

For Multi cards/PINs access mode, the interval time of reading cards/inputting PINs can not exceed 5 seconds, or else, the XK Series Device will exit to standby automatically.

Programming Step	Keystroke Combination
1. Enter Program Mode	* (Master Code) #
2. Card access OR 2. Card + PIN access OR 2. Card or PIN access OR 2. Multi cards/PINs access	4 0 # 4 1 # 4 2 # 4 3 (2~9) # (Only after reading 2~9 cards or inputting 2~9 PINs, the door can be opened)
3. Exit	*

Simplified Instruction	
Function Description	Operation
Enter the Programming Mode	* - 123456 - # then you can do the programming (123456 is the factory default master code)
Change the Master Code	0 - New Code - # - Repeat the New Code - # (code: 6 digits)
Add Card User	1 - Read Card - # (can add Cards continuously)
Add PIN User	1 - PIN - #
Delete User	2 - Read Card - # for Card User 2 - PIN - # for PIN User
Exit from the Programming Mode	*
How to release the door	
Card User	Read Card
PIN User	Input PIN #

Set Strike-out Alarm

The strike-out alarm will engage after 10 failed entry attempts (Factory is OFF). It can be set to deny access for 10 minutes after engaging or disengage only after entering a valid card/PIN or Master code.

Programming Step	Keystroke Combination
1. Enter Program Mode	* (Master Code) #
2. Strike-Out OFF OR 2. Strike-Out ON OR 2. Strike-Out ON (Alarm) Set alarm time	6 0 # (factory default) 6 1 # Access will be denied for 10 minutes 6 2 # 5 (0 ~ 3) # (factory default is 1 minute) Enter Master code # or valid user card / PIN to silence
3. Exit	*

Set Audible and Visual Response

Programming Step	Keystroke Combination						
1. Enter Program Mode	* (Master Code) #						
2. Control Sounds OR 2. Control LED OR 2. Control Keypad Backlit	<table border="0"> <tr> <td>OFF = 7 0 #</td> <td>ON = 7 1 #</td> </tr> <tr> <td>OFF = 7 4 #</td> <td>ON = 7 5 #</td> </tr> <tr> <td>OFF = 7 6 #</td> <td>ON = 7 7 # (Factory defaults are ON)</td> </tr> </table>	OFF = 7 0 #	ON = 7 1 #	OFF = 7 4 #	ON = 7 5 #	OFF = 7 6 #	ON = 7 7 # (Factory defaults are ON)
OFF = 7 0 #	ON = 7 1 #						
OFF = 7 4 #	ON = 7 5 #						
OFF = 7 6 #	ON = 7 7 # (Factory defaults are ON)						
3. Exit	*						

Set Card Reading Type (This step can only be applied to HID & EM version)

Programming Step	Keystroke Combination
1. Enter Program Mode	* (Master Code) #
2. Read HID & EM card OR 2. Read EM card ONLY OR 2. Read HID card ONLY	9 3 # (factory default) 9 4 # 9 5 #
3. Exit	*

Master Cards Usage

Using Master Cards to add and delete card users	
Add a User	<ol style="list-style-type: none"> 1. (Read Master Add Card) 2. (Read User Card) Repeat Step 2 for additional user cards <ol style="list-style-type: none"> 3. (Read Master Add Card)
Delete a User	<ol style="list-style-type: none"> 1. (Read Master Delete Card) 2. (Read User Card) Repeat Step 2 for additional user cards <ol style="list-style-type: none"> 3. (Read Master Delete Card)

Users Operation & Reset to Factory Default

- > **Open the door:** Read valid user card or inputting valid user PIN
- > **Remove Alarm:** Read valid user card or inputting valid user PIN, or input

Master Code #

- > **To reset to factory default & Add Master Cards:** Power off, press the Exit Button, hold it and power on, there will be two beeps, and the LED light turns into yellow, release the exit button, then read any two 125KHz EM cards or HID cards, the LED will turn into red, means reset to factory default successfully. Of the two cards reading, the 1st one is Master Add Card, the 2nd one is the Master Delete Card.

Remarks:

- ① If no Master Cards added, must press the Exit Button for at least 10 seconds before release.
- ② Reset to factory default, the user's information is still retained.

CONTROLLER MODE

The XK Series Device can work as Controller, connected with the external Wiegand reader. (Factory default mode)---7 2 #

Connection Diagram

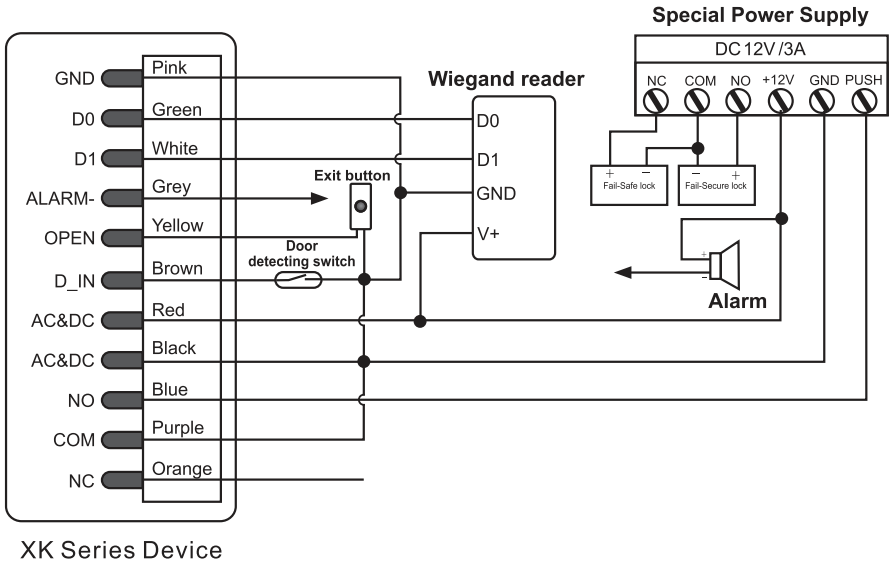

Attention: Install a 1N4004 or equivalent diode is needed when use a common power supply, or the reader might be damaged. (1N4004 is included in the packing)

Set Wiegand Input Formats

Please set the Wiegand input formats according to the Wiegand output format of the external Reader.

Programming Step	Keystroke Combination
1. Enter Program Mode	* (Master Code) #
2. Wiegand input bits	8 (26~37) # (factory default is 26 bits)
3. Exit	*

Programming

> Basic Programming is the same as Standalone Mode

> There are some exceptions for your attention:

The XK Series Device connected with External Card Reader:

- If EM card reader or HID card reader: users can be added/deleted on either the XK Series Device or external reader.
- If Mifare reader: users **can only be** added/deleted on external reader.

The XK Series Device connected with Fingerprint Reader:

For example:

Connect F2 as the fingerprint reader to the XK Series Device, it is of two steps to enroll the valid fingerprint.

Step 1: Add the Fingerprint (A) on F2

Step 2: Add the same Fingerprint(A) on the XK Series Device:

1	Enter Program Mode: * (Master Code) #
2 or 2	1 (Press Fingerprint A once on F2) # (ID auto allocated) 1 (User ID) # (Press Fingerprint A on F2) # (Select specific ID)
3	Exit: *

The XK Series Device connected with Keypad Reader:

The keypad reader can be 4 Bits, 8 Bits (ASCII), or 10 Bits output format.

Choose the below operation according to the PIN output format of your reader.

Programming Step	Keystroke Combination
1. Enter Program Mode	* (Master Code) #
2. Wiegand input bits	8 (4 or 8 or 10) # (factory default is 4 bits)
3. Exit	*

Remarks: 4 means 4 bits, 8 means 8 bits, 10 means 10 digits virtual number.

> Add PIN Users:

To add PIN users, after enter into programming mode on the XK Series Device, PIN(s) can be input/ added on either the XK Series Device controller or the external Keypad Reader.

> **Delete PIN Users:** the same way as add users.

WIEGAND READER MODE ---

The XK Series Device can work as Standard Wiegand Reader, connected to the third party Controller--- 7 3 #

Notes:

The EM version reads EM card only, while the HID & EM version can be set to read HID & EM cards, or HID card only, or EM card only. Factory default card type of the HID & EM version is HID & EM cards, if you want to change the type, please set the XK Series Device to Standalone Mode (7 2 #) and then set the type. (See page 11 for setting card type).

Connection Diagram

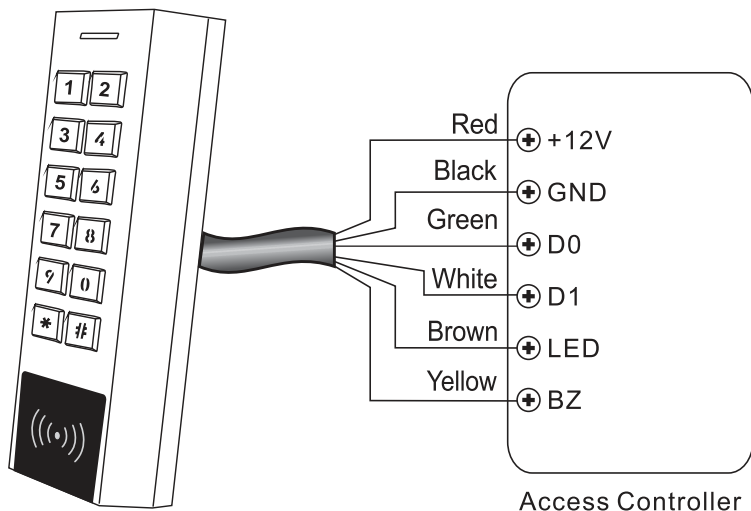

XK Series Device

Notes:

> When set into Wiegand Reader mode, nearly all settings in Controller Model will become invalid. And Brown & Yellow wires will be redefined as below:

- Brown wire: Green LED light control
- Yellow wire: Buzzer control

> If you need to connect Brown/Yellow wires:

When the input voltage for LED is low, the LED will turn into Green; and when the input voltage for Buzzer is low, it will sound.

Set Wiegand Output Formats

Please set the Wiegand output formats of Reader according to the Wiegand input formats of the Controller.

Programming Step	Keystroke Combination
1. Enter Program Mode	* (Master Code) #
2. Wiegand output bits PIN output bits	8 (26~37) # (factory default is 26 bits) 8 (4 or 8 or 10) # (factory default is 4 bits)
3. Exit	*

ADVANCED APPLICATION

User Information Transfer

The XK Series Device supports the User Information Transfer function, and the enrolled user (cards, PINs) can be transferred from one (let's name it Master Unit) to another (let's name it Accept Unit)

Connection Diagram:

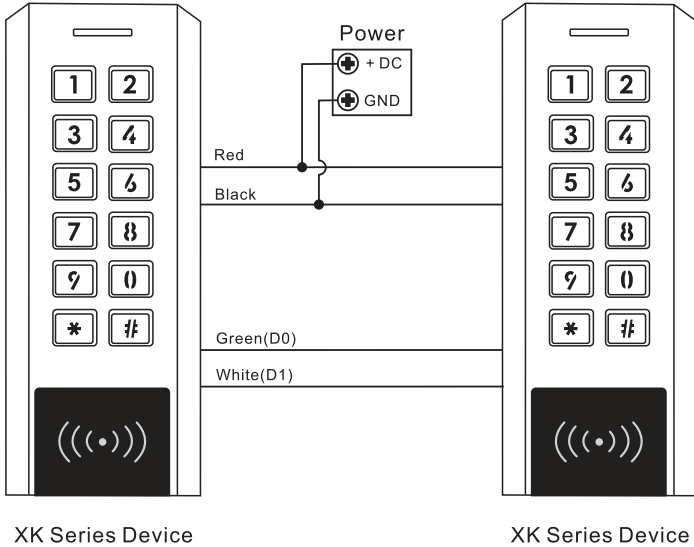

XK Series Device

XK Series Device

Remarks:

- > The Master units and Accept units must be XK Series Device or SK2/SK5 or S-X series or Sboard.
- > The Master Code of the Master Unit and the Accept Unit must be set to the same.
- > Program the transfer operation on Master Unit only.
- > If the Accept Unit is already with the users enrolled, it will be covered after transferring.
- > For full 1000 users enrolled, the transfer takes 3 minutes.

Set Transferring on Master Unit:

Programming Step	Keystroke Combination
1. Enter the programming mode	* (Master Code) #
2. Set transferring	9 6 #
Within 3 minutes, Green LED shines, after one beep, the LED will turn into Red, which means the users' information has been transferred successfully.	
3. Exit	*

Interlock

The XK Series Device supports the Interlock function. It is of two keypads for two doors, and mainly used for banks, prisons, and other places where a higher level security is required.

Connection Diagram:

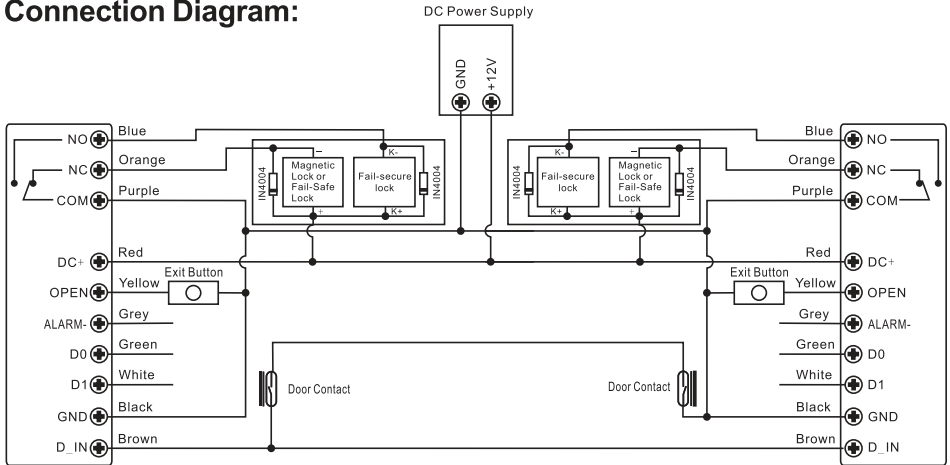

XK Series Device

XK Series Device

Remarks: The Door Contact must be installed and connected as the diagram. Let's name the two Keypads as "A" and "B" for two doors "1" and "2"

Step 1:

Enroll the users on Keypad A, then transfer the users' information to Keypad B by "User Information Transfer" function.

Step 2:

Set both of the two Keypads (A and B) to Interlock function

Programming Step	Keystroke Combination
1. Enter Program Mode	* (Master Code) #
2. Interlocked-OFF OR 2. Interlocked-ON	9 0 # (factory default) 9 1 #
3. Exit	*

The interlock operation is finished, When and only door 2 is closed, the user can read the valid card or input PIN on Keypad A, door 1 will open; then when and only door 1 closed, read valid card or input PIN on Keypad B, door 2 will open.

For Inquiries, Please Contact:

Security Shop
Vladimira Popovica 6/6/A606
11070 Novi Beograd, Serbia
Tell +381 11 318 68 68
office@securityshop.rs