

# HYUNDAI

## INDOOR MONITOR

HYU-IN-IMO7002

User manual



- Please read this manual carefully before using the product you purchase, and keep it well for future use.
- Please note that images and sketch maps in this manual may be different from the actual product.

# Contents

1.Parts and Functions.....	1
2.Mounting.....	2
3.Main Menu.....	2
4. Status Bar Icons .....	5
5.Answering a Call.....	6
6.Monitoring.....	7
7.Main Menu Switching.....	7
8.Favorite Setting.....	8
9.PIP View .....	8
10.Quad View .....	9
11.Makding Calls .....	10
12.View Call Record .....	11
13.No Disturb Mode.....	12
14.Divert Calls .....	13
15.Change the Monitor's Settings.....	13
16.Address Setup .....	16
17.Upgrade.....	17
18.How to add IP camera to IP monitor.....	19
19.Download Setup VDP Connect APP.....	21
20.Surveillance door station VDP Connect APP.....	22
21.Specification .....	23
22.Precautions.....	23

# 1. Parts and Functions

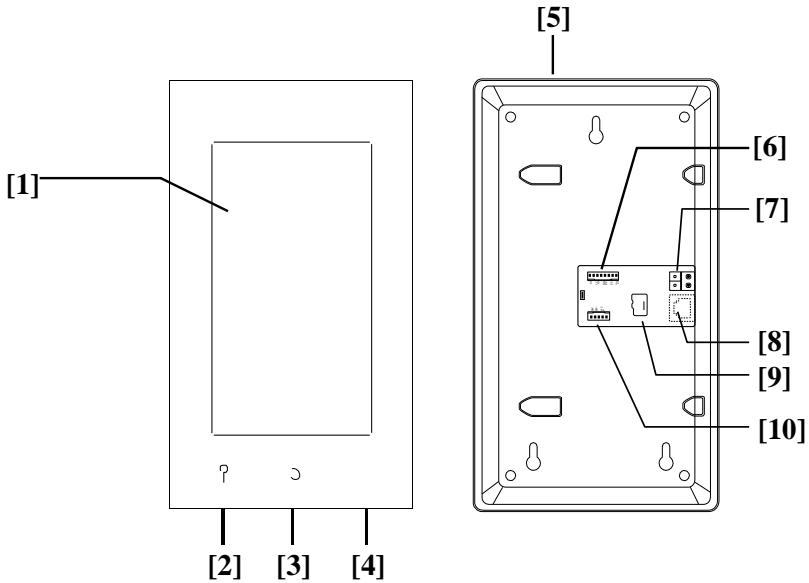

## Key functions

NO.	Item	Description
[1]	Digital LCD touch screen	See the next page for details Display the visitors' image
[2]	Unlock button	Press to release the door
[3]	Talk/Mon button	Press to communicate hands free with visitor Press to view the outdoor condition in standby mode
[4]	Power/No Disturb indicator	Show the power status of the system. Show the no disturb status.
[5]	Speaker	Send out sounds of ring tones, audios and alarms
[6]	Alarm zone	Reserved
[7]	2 wire connector	Reserved for 2 wire system.
[8]	Lan connector	Use to connect the indoor station to the network.
[9]	SD card slot	Use to insert micro-SD card
[10]	Terminal connector	SW+,SW-: Extra door bell call button connection port. P+,P-: Use to connect 24V local power supply (HDR-30-24).

## 2. Mounting

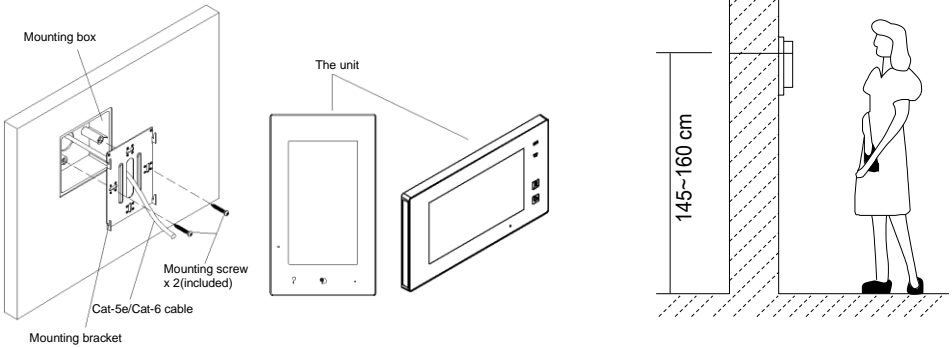

The installation height is suggested to 145~160cm.

1. Use screws to fasten the mounting bracket to the wall with mounting box.
2. Connect the cat-5e or cat-6 cables to the unit.
3. Mount the unit to the mounting bracket, make sure the unit is absolutely attached to the mounting bracket.

## 3. Main Menu

The Main menu is your starting point for using all the applications on your monitor.





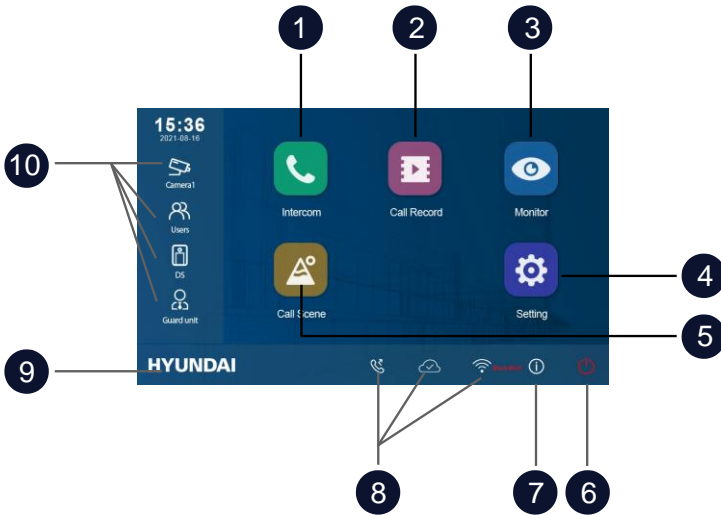



Touch **Unlock** button, or touch anywhere of the screen on monitor in standby mode, the Main menu will appear as follow:

# The main menu of HYU-IN-IMO7002





- 1 Intercom icon**  
Allows you to call other indoor station.
- 2 Call Record icon**  
Allows you to view the call record.
- 3 Monitor icon**  
Allows you to monitor the door stations, cameras.
- 4 Setting icon**  
Use to change the indoor station's settings.
- 5 Call Scene icon**  
Allows you to activate the functions of No disturb, Divert.
- 6 Close icon**  
Touch to turn off the screen.
- 7 About icon**  
Allows you to view the information about device.
- 8 Status bar**  
Displays icons that indicate the indoor station's status(see 4. Status bar icons(page4)).
- 9 Logo**  
Shows "2EASY-IX" by default. Means the brand of indoor station. Can be customized.
- 10 Shortcut windows**  
Touch to enter the corresponding items directly.

## 4. Status Bar Icons



Icon	Description	
	Missed call	Display when there is missed call unread. Touch to review the missed call in shortcut.
	No disturb	Indicates the device is in “No disturb” mode.
	Divert call	Indicates the device is in “Divert call” mode.
	Device online	Indicates device online, but not connect to internet.
	Cloud server worked	Indicates the device is connected to the cloud server.
	No cloud server	Indicates the device is not connected to the cloud server.
	Cloud server anomaly	Indicates the device cloud server connection is abnormal.
	mute	Indicates the device is in “Mute” mode.

### Other status icons



Icon	Description	
	Recording	Indicates the device is recording
	Talking	Indicates the device is in “talking” status.
	Unlock	Indicates open the corresponding door.

## 5. Answering a Call

When you receive a call, the indoor station rings. Image will be displayed on the screen.

1. Touch  icon or press  **TALK/MON** button.

- Speak within about 50 cm of the microphone.
- Begin communicating hands free with the visitor for 90 seconds.

2. When finished, Touch  icon or press  **TALK/MON** button again.

Available functions while talking on a call

- Door release
- Manual recording

### Notes:

#### **1.Receiving a call while talking with a door station**

- Other door stations calling is forbidden
- Conclude current talking to answer the new call-in

#### **2.Receiving a call while talking with other monitors**

- The talking will stop immediately, call tone sounds in normal.
- The video image from the door station is displayed on the screen, talking,unlock,capture images/videos are available.

# 6. Monitoring

This section can be used to monitor your home by enabling one of the cameras inside the apartment, the common areas (e.g. garages, garden), and at the entrance.

1. From the main menu, tap **"Monitor"** icon.
2. Select the desired tap.
  - Allows you to select door station camera or IP camera( if the system installs multi door station or IP camera) .
3. Select the desired camera.
4. When finished, tap  button on panel.

\* During monitoring, images can be viewed, but audio cannot be heard.

Available functions during monitoring:

- Door release
- Manual recording

**Note:** Tap monitor quick actions to monitor corresponding camera directly(If the monitor quick actions is set on the shortcut windows).

# 7. Main Menu Switching

This section can be used to switch the menu for HYU-IN-IMO7002.

The Steps are as follows:

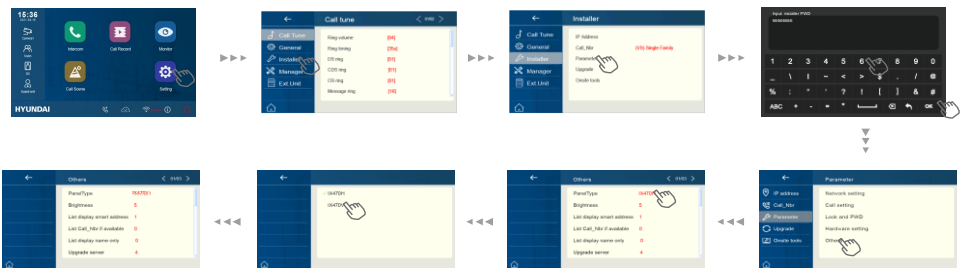

After restart, you can switch to the new menu.



**\*All of the following have been explained by taking the HYU-IN-IMO7002 menu as an example.**

## 8. Favorite Setting

This section can be used to set your favorite.

1. From the main menu, tap **"Monitor"** icon.  
- A list of available setting categories is displayed.
2. Select "Monitor" item.
3. Click the upper left corner of the item you need to select, and then the "★" icon will appear.
4. If you need to cancel, click the upper left corner again.



## 9. PIP View

Precondition: this function requires the system to access the cameras or set the camera proxy settings.

The picture-in-picture display allows the user to see two images from different sources at the same time during the call, which is convenient for the user to see the visitor intuitively and concretely.

Press call button  
on door station



## Feature of PIP view:

- in call mode
- Picture in picture to avoid dead corner
- Able to watch both views from door station and IP camera
- Swap the two images by a simple touch

## 10. Quad View

Precondition: this function requires the system to access the cameras or set the camera proxy settings.

The Quad display allows the user to view four images quickly and simultaneously from different video resource, and to quickly switch & zoom in on a screen by one click.



## Feature of quad view:

- In monitor mode
- Able to display four images at a screen
- switch seamlessly between One-view and Quad-view
- free to zoom in any views

# 11. Making Calls

You can call other residences, common area phones or facility staff office, and even other rooms in your own residence.

whichever monitor answers the call, you can use many of the features described in feature available while talking on a call.

## **Namelist call by using the namelist**

1. From the main menu, tap "**Intercom**" icon.
  - A list of available items is displayed.
2. Select "Namelist".
  - A list of name is displayed if the system allows.
3. Select the desired name.
  - Calling the target directly.

## **Inncall**

If you have monitors installed in different rooms in your residence, you can call those rooms and use the system as an intercom.

1. From the main menu, tap "**Intercom**" icon.
  - A list of available items is displayed.
2. Select "Inner call".
  - A list of M/S is displayed.
3. Select the desired target.
  - Calling the target directly.

## **Calling guard station**

1. From the main menu, tap "**Intercom**" icon.
  - A list of available items is displayed.
2. Select "Guard station".
  - Calling the target directly.

## 12. View Call Record

The monitor records information about calls you have answered, missed, and made, and saves it in the call record. See the following steps to view the call record.

1. From the main menu, tap **"Call record"** icon.
2. Select the desired tap.
  - Missed: Displays calls you received but did not answer.
  - Incoming: Displays calls you answered.
  - Outgoing: Displays calls you made.
  - Playback: Displays pictures/videos you received / made.
3. Browse the call record as needed.
4. When finished, tap ← , return to previous menu.(or tap  return to home page)

### Play videos

you can record camera video manually while talking to a visitor or monitoring camera video. See the following steps to play the video.

1. From the main menu, tap **"Call record"** icon.
2. Select the desired tap.
3. Tap the desired call record.
  - Displays the images/videos
4. When finished, tap ← .

### Controlling video playback

The following controls are available by tapping the screen while playing a image/video.



Plays the video.

 Plays the next video.

 Plays the previous video.

 Delete video.

 Delete confirm.

### **Note :**

1. If without SD card, video recording time is 3 seconds. Up to 10 videos can be saved, Subsequent records will overwrite the oldest items.  
If with SD card, video recording time is 10 seconds by default (Max 600 seconds could be set or customized).
2. Support 512G SD card.

## **13. No Disturb Mode**

During a certain period, if you don't want to be disturbed, you can go to set DND mode.

1. From the main menu, tap "**Call scene**" icon.
2. Select the desired tap.
  - No disturb 8H: Set to no disturb mode 8 hours.
  - No disturb always: Set to no disturb mode always.

Note:

\* The no disturb indicator turns from green to red, to indicate that the no disturb function has been activated.

\* This function will perform immediately if selected, and the status bar on main menu interface will show "" icon.

## 14. Divert Calls

The calling from door station can be diverted to your smart phone. please note that this function should be supported by SIP network.

1. From the main menu, tap "**Call scene**" icon.
2. Select the desired tap.
  - Divert call if no answer: If nobody answers the call in 30s when receives call from door station, diverts the call to the smart phone. At this mode, the monitor will always open the screen and show image from door station during diverted, if the monitor answers the call at this time, diverted will conclude at once.
  - Divert call always: When receives call from door station, diverts the call to smart phone directly. At this mode, the monitor will shut off the screen after diverting successfully, but you can still use it in normal.

Note:

- \* If divert the call to smart phone via Sip sever, need to choose one.
- \* This function will perform immediately if selected, and the status bar on main menu interface will show " " icon.

## 15. Change the Monitor's Settings

1. From the main menu, tap "**Setting**" icon.
  - A list of available setting categories is displayed.
2. Select the desired tap.
3. Select the desired setting category.
4. Change the settings as desired.
5. Tap ← /  to save the new setting.

## List of settings

 all Tune	<a href="#">Ring volume</a> - <a href="#">Ring timing</a> - <a href="#">DS ring</a> - <a href="#">CDS ring</a> - <a href="#">OS ring</a> - <a href="#">Message ring</a> - <a href="#">Doorbell ring</a> - <a href="#">Intercom ring</a> - <a href="#">Innercall ring</a> - <a href="#">Alarm ring</a>
 General	<a href="#">Date and time</a> - <a href="#">Language</a> - <a href="#">Monitor timing</a> - <a href="#">Shortcut setting</a> - <a href="#">SD card</a> - <a href="#">Auto close after unlock</a> - <a href="#">Auto unlock</a> - <a href="#">Name</a>
 Installer	<a href="#">IP address</a> - <a href="#">Call_Nbr</a> - <a href="#">Parameter</a> - <a href="#">Upgrade</a> - <a href="#">Onsite tools</a>
 Manager	<a href="#">Sip config</a> - <a href="#">Private unlock code</a> - <a href="#">Common unlock code</a> - <a href="#">Card manager</a> - <a href="#">Back and restore</a>
 xt.Unit	<a href="#">Auto setup wizard</a> - <a href="#">IM extensions</a> - <a href="#">Outdoor Stations</a> - <a href="#">IPC camera</a> - <a href="#">Enter OS binding</a> - <a href="#">WLAN</a> <a href="#">IPC camera</a>

### Example: "DS ring" setting

1. From the main menu, tap "**Setting**" icon.
  - A list of available setting categories is displayed.
2. Select "Call Tune", and then tap "DS ring" item.
  - A list of available tune is displayed.
3. Select the tune as desired, and tap.
4. Tap ← / 🏠 to save the new setting.

**Ring volume:** adjust the ringtone volume.

**Ring timing:** adjust the ringtone time.

**DS ring:** call tone from door entrance panel.

**CDS ring:** call tone from common door entrance panel.

**OS ring:** call tone from out door entrance panel.

**Message ring:** call tone when received message.

**DoorBell ring:** call tone from doorbell.

**Intercom ring:** call tone from an intercom of another apartment.

**Innercall ring:** call tone from an intercom in your apartment.

**Alarm ring:** call tone when alarm.

**Example:** "Date and time"setting

1. From the main menu, tap "**Setting**" icon.
  - A list of available setting categories is displayed.
2. Select "General", and then tap "Date and time" item.
  - Date and time seting interface is displayed.
3. Select and change the settings as desired.
4. Tap ← / 🏠 to save the new setting.

**Date mode:** 2 display mode: month/date/year and date/month/year

**Time mode:** 2 display mode: HOUR\_12 and HOUR\_24.

**Date:** touch it to set the date .

**Time:** touch it to set the time.

**Internet time:** touch it can synchronize the system time.

**Example:** "Language"setting

1. From the main menu, tap "**Setting**" icon.
  - A list of available setting categories is displayed.
2. Select "General", and then tap "Language" item.
  - Language interface is displayed.
3. Select and change the settings as desired.
4. Tap ← / 🏠 to save the new setting.

**Example:** "Shortcut setting"

1. From the main menu, tap "**Setting**" icon.
  - A list of available setting categories is displayed.
2. Select "General", and then tap "Shortcut setting" item.
  - Shortcut setting interface is displayed.
3. Select the type of function for which you want to add/remove a quick action.
4. Tap ← / 🏠 to save the new setting.

**Note:** Other settings are related to the system type. Please make settings according to the functions provided by your system.



# 16. Address Setup

1. From the main menu, tap "**Setting**" icon.
  - A list of available setting categories is displayed.
2. Select "Installer", and then tap "Call\_Nbr" item.
3. Input password if required (66666666 by default).

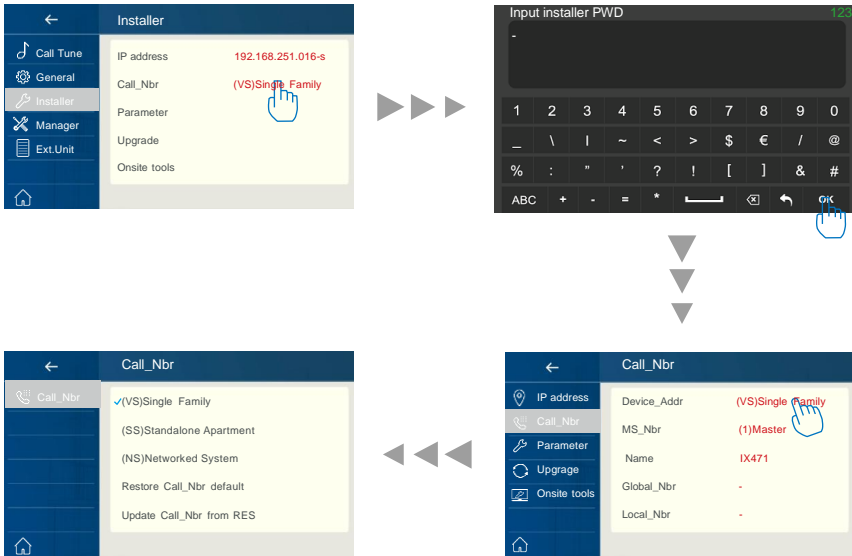

## Device\_Addr:

"(VS)Single Family": For villa single one-to-one installation, no need to input room number.

"(SS)Standalone Apartment": for standalone building, tap to input room number ( 1-digit, 2-digit, 3-digit, 4 digit as you defined).

Ex: Tap "(SS)" and input 0001 for room standalone building.

"(NS)Networked System": for standalone building, input 8digits number(must 8-digit input), first 4digits for building/block number, last 4digits for room number.

EX: 00010003 1st building 3rd monitor; 00030005 3rd building 5th monitor

"Restore/Update from RES": Reserve for configurations database file (RES file) update and backup.

MS\_NBR:

Master and slave number, 01 is master monitor, 02~32 is slave monitor.

Name:

The "Name" input here will sync to door station's calling list automatically.

Global\_Nbr:

Extra call number for common door station calling to this monitor.

Local\_Nbr:

Extra call number for door station in same building calling to this monitor

## 17. Upgrade

1. From the main menu, tap "**Setting**" icon.  
- A list of available setting categories is displayed.
2. Select "Installer", and then tap "Upgrade" item.
3. Input installer password (66666666 by default, or password free when door station into installer mode and enable it)

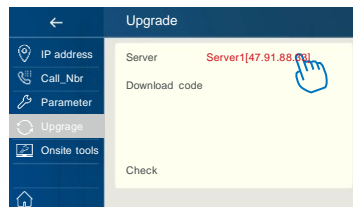
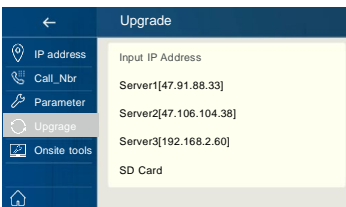
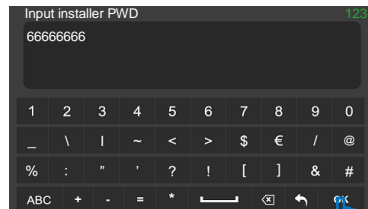
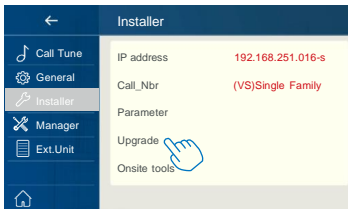

Tap “Server” to select firmware source, update firmware could come from as below, tap on the source:

1. **Cloud Server**

Cloud server requires internet.

**Server1[47.91.88.33]**

**Server2[47.106.104.38]**

2. **Local LAN server (IX -Builder)**

Use IX-Builder PC software to create a temporary local server for update.

**Server3[192.168.2.60]** #IX-Builder default IP

**[Input IP address]**

3. **SD card**

Copy upgrade firmware before upgrade.

**SD card**

After tap “Download code” and input code, the code could get from v-tec support team when device needed to update. After all, tap “Check” to load upgrade information from source.

With tips on the screen as below:

**Please insert SD card.** #Some upgrade is oversized, require SD card to store firmware.

**Mismatched.** #Update firmware was founded, but is not suitable for this device.

**Connect Error.** #Check networks.

**No file.** #Source has been inspected but there is no firmware need to upgrade.

Otherwise the device will go into upgrade automatically, please do not power off during upgrade.

# 18. How to add IP camera to IP monitor

## Preparation

Select the appropriate IP camera to access the system on demand. And set parameters for the IP camera.

### Video Codec

An Onvif IP camera could be added to IP monitor IX471S, as long as this IPC could support following video codec: H264B/H264/H264H/H265/H265+

- \* 1. MJPEG decoding is not supported.
- 2. Some IPC can support both audio and video streams, please select video stream.

### ***Preset the IP Camera before establishing a connection to the IX monitor***

The setting interface of each IP camera brand are different. Please set the following items according to the actual situation.

### Network

Choose to set DHCP or STATIC depending on the system.

### Video

Each stream type need to do setting separately.

	Main Stream (Full screen)	Sub Stream ( Quad-view)	Tri-Stream ( App view)
Encoding	H264 or H265, MJPEG is not support		
Resolution	1280*720	640*480	320*240
FPS( Frames per second)	acceptable setting range: 15 ~ 18, 15 is the Best recommendation		
Bit Rate	700~1024kbs	512kbs~640kbs	512kbs~640kbs
BitRate Control	CBR is the Best recommendation		

# Add IP Camera to HYU-IN-IMO7002 on site

## 1. Select the correct menu according to the actual situation

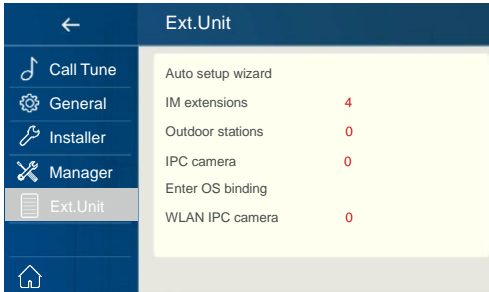

It depends on how the monitor is connected to the router where the IPC is located.

If it is wireless connected to PoE or Router which IPC attached , select **WLAN IPC camera** to add.

If it is wired connected to PoE or Router which IPC attached , select **IPC camera** to add.

see below samples:

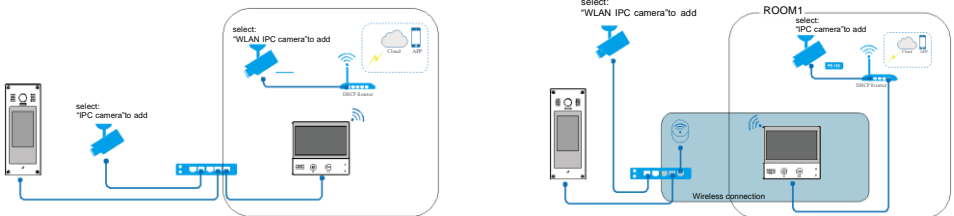

## 2. Add by search or manual.

### 3. Login

### 4. Save

## Delete IP camera

main menu → Settings → Ext.Unit → IPC camera / Wlan IPC camera → chose → Delete

## 19. Download Setup VDP Connect APP

1. Scan and download VDP Connect APP, or search “VDP Connect” on APP store.

IOS



Android



2. Permit “VDP Connect” with permissions, tap screen of IP monitor → Settings → Manager → SIP config → .

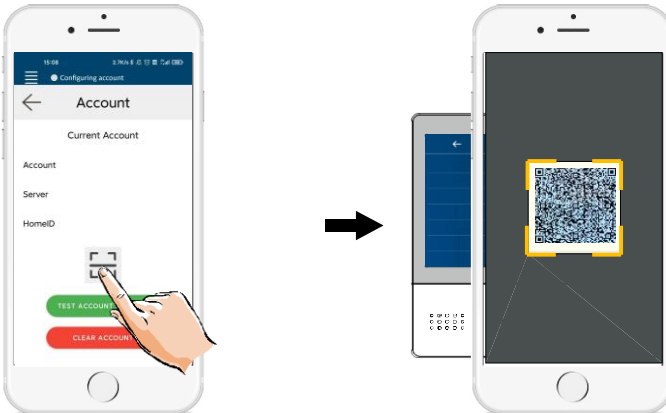

3. After login SIP account on VDP Connect APP, check on status bar, or tap on the “Connected” area to manually register, until VDP Connect display:



## 20. Surveillance door station via VDP Connect APP

On VDP CONNECT APP, press on the icon and wait for a few second. If the system have multiple door stations,you can switch to view the door station you want. And push PTT icon to talk, or push unlock icon to open the door.



## 21. Specification

- Power Source: Power-over-Ethernet (IEEE 802.3af Class 0)
- LAN Interface: 10 BASE-T / 100 BASE-TX Ethernet (RJ-45)
- Monitor screen: 7" IPS full view angle TFT
- Display Resolutions: 1024\*600 resolution
- Wire Type: Cat-5e or Cat-6
- Wiring Distance: 100m (Approx. 330')
- Operating temperature: -10 to +50 (oC)
- Dimension: 174(H)×161(W)×22(D)mm

## 22. Precautions

- 1) All components should be protected from violence vibration. And not allow to be impacted, knocked and dropped.
- 2) Please do the cleanness with soft cotton cloth, please do not use the organic impregnant or chemical clean agent. If necessary, please use a little pure water or dilute soap water to clean the dust.
- 3) Image distortion may occur if the video monitor is mounted too close to magnetic field e. g. Microwaves, TV, computer etc.
- 4) Please keep away the monitor from wet, high temperature, dust, caustic and oxidation gas in order to avoid any unpredictable damage.
- 5) Must use the right adaptor which is supplied by the manufacturer or approved by the manufacturer.
- 6) Pay attention to the high voltage inside the products, please refer service only to a trained and qualified professional.



# Note

A series of 20 horizontal dashed lines for writing notes.

# Note

A series of 20 horizontal dashed lines for writing notes.

# HYUNDAI

**For Inquiries, Please Contact:**

**Security Shop  
Vladimira Popovica 6/6/A606  
11070 Belgrade, Serbia  
Tel: +381 11 318 68 68  
office@macchina.rs**

Imported/Distributed by Security Shop doo  
Licensed by Hyundai Corporation Holdings, Korea  
Delivery and After Service shall only be covered within Serbia